

## Website Design at SDN Cipete Utara 07

Eri Mardiani<sup>1</sup>, Nur Rahmasyah<sup>2</sup>, Ira Kurniati<sup>3</sup>

<sup>1</sup>Department of Informatics, FTKI, Universitas Nasional, Indonesia  
Jl. Sawo Manila No.61, RW.7, Pejaten Bar., Ps. Minggu, Jakarta Selatan  
<sup>2,3</sup>Department of Animation, Politeknik Negeri Media Kreatif, Indonesia  
Jl. Srengseng Sawah Raya No.17, RT.8/RW.3, Jagakarsa, Jakarta Selatan

### ABSTRACT

*The easiest way to introduce information to the public is to use technological developments, currently technology is a part of everyday life. Technology is needed in all fields, one of which is in the field of education, for the information society education is needed to know the condition of education in Indonesia, because education is a very important factor for society to increase intelligence, other factors with the use of technology are the most important. much needed by using technological facilities utilizing both desktop and web-based applications can help human activities. so in the world of education also keep abreast of developments, because of current demands that require society to better understand technological developments, schools need to continue to innovate in improving services and more comprehensive interaction with student guardians in particular and society in general. One of them is by utilizing internet media (school website). Departing from these needs, schools need to have media that can be used as a means of interaction between the school and the community and as a means of school existence in cyberspace, and to introduce schools to the community, schools must also be able to provide facilities that are easily known, one of which is using website. With a website, more information about the school can be provided to the public. In addition, the website also raises the status of the school.*

**Keywords:** Website, UML, School, PHP, SQL

### Introduction

There are many technological advancements available with computers. Computers not only help us get work done, they can also be fun and useful tools to use. To further maximize work, internet-based technology strongly supports online work [1]. In addition, with internet technology, work is much faster and easier to complete than using a traditional computer. The development of information technology has been so rapid. Internet technology connects thousands of individual computer networks and organizations around the world [2].

Currently education is the main capital for a nation in an effort to improve the quality of its human resources. Quality human resources will be able to manage natural resources and provide services effectively and efficiently to improve people's welfare. Therefore, almost all nations are trying to improve the quality of education they have, including Indonesia [3].

Basically improving the quality of education based on schools. Schools are the basis for quality improvement, because schools know more about the problems faced in improving the quality of education. Schools function as units that develop curricula, syllabus, learning strategies and assessment systems. Thus school management is the basis for improving the quality of education[4].

SDN Cipete Utara was founded in 1975, and from year to year the number of students at this school has decreased due to the location of the school which is quite far from the main road [5]. Because of that, a website was made about SDN Cipete Utara 07 with the intention of introducing this school to the public, one alternative to the problems that occur in the progress of the Cipete Utara 07 Public Elementary School apart from brochures and banners is also made to promote the school online, and based on the analysis, it is concluded that by creating a website, more information about the school can be provided to society, especially for the people [6]. Because using the system will facilitate human activities with a small error risk, although there are still activities that are easier to use manually [7].

### Research Methods

This study prioritizes the use of methods that are in accordance with the subject matter of the research being conducted, for the method used is the waterfall method because a systematic and sequential approach is needed in building the system. Cascading flow is that the system is written sequentially[8]–[12]. The resulting

system produces very good quality because the implementation is gradual and not focused on a particular phase [13].

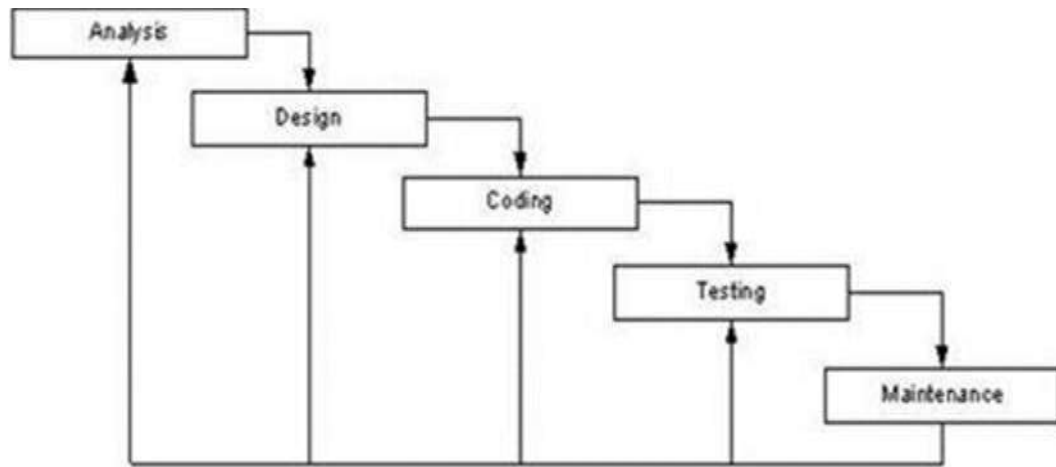

**Figure 1** Waterfall method

At the stage of developing a system, this method is systematic, and the series in the software design system are carried out sequentially [14]–[21]. The waterfall method or also called the waterfall method is a method that is often used to update the application system that is currently running. There are several stages in this method, namely application analysis, application design, application implementation, application testing, and maintenance. At this stage, coding is done using a programming language. The programming language used for this research are HTML, CSS, PHP, and MYSQL as the database [22]–[26].

### Results and Discussion

Information technology has become a curriculum starting from elementary to high school level. The more knowledge students get, the more students take advantage of technological advances to obtain information, one of which is the use of the internet.

To keep up with current technological advances, many schools have created websites so that their schools can be accessed via the internet, as a medium of information and promotion.

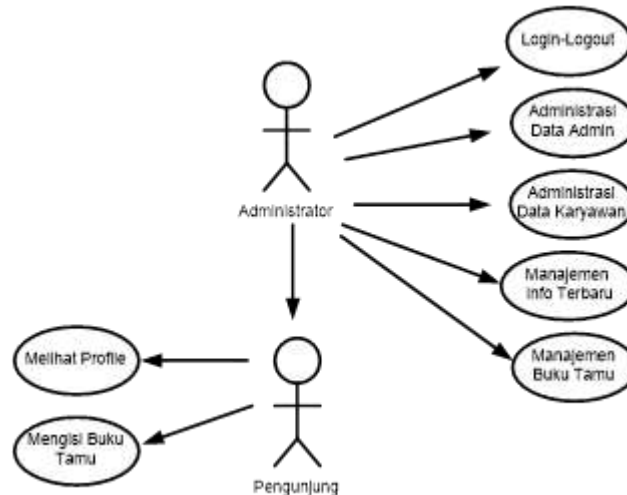

**Figure 2** Use Case Diagram Users and Admins

**Table 1** Use Case Documentation Viewing Profile  
View Profile

Actor : All Users
Initial Condition: User is on the home page
Final Condition: Getting school information

Description : Features to view school profiles

Basic Flow :

Action Actors	System Response
	1. The system displays the home page of the website
2. Visitors choose the school's profile page	
	3. The system displays the school profile page

Extentions (or Alternate Flows) :

**Table 2** Use Case Documentation Filling the Guestbook

Filling out the guestbook

Actors : All users

Initial Condition: User is on the home page

Final Condition: Filling in guest data and messages on the guestbook page successfully

Description : Features to view and fill in the guestbook

Basic Flow :

Action Actors	System Response
	1. The system displays the home page of the website
2. Visitors choose guestbook pages	
4. Visitors view or fill in the guestbook and send or save to the guestbook table	3. The system displays the guestbook page
	5. The system displays the results of the guest book that has been filled.

Extentions (or Alternate Flows) :

**Table 3** Login Use Case Documentation

Login

Actor : Administrator

Initial Condition: Prospective User is on the login page

End Condition: User successfully logged in the system

Description : Features to authenticate system users

Basic Flow :

Action Actors	System Response
1. Prospective users enter their username and password	
	2. The system validates the username and password entered
	3. The system displays the main page according to the user status

Extentions (or Alternate Flows) :

**Table 4** Admin Data Administration Use Case Documentation

Admin data administration

Actor : Administrator.

Initial Condition: The administrator is on the admin records page.

End Condition: Admin data administration is successful.

Description : Features to add, change, and Delete admin data

Basic Flow :

Action Actors	System Response
1. Admin selects menu for admin data administration	
	2. The system displays a registration menu and edit admin data
3. Admin performs an administrative action	
	4. The system validates the administrative fields
	5. The system executes admin actions and records changes that occur
	6. The system displays the results of administration

Extentions (or Alternate Flows) :

- 3 a. Admins perform actions to add admin data
  - 1). Admin enters admin data
  - 2). Admin saves admin data
- 3 b. Admins perform actions to modify admin data
  - 1). Admin changes admin data
  - 2). The admin chooses to save the changes
- 3 c. An admin performs an action to delete admin data
  - 1). Admin deletes one admin record
- 6 a. The system displays the results of administration adding admin data
  - 1). The system displays a list of admin data with increased admin data
- 6 b. The system displays the results of administration change admin data
  - 1) The system displays a list of admin records with changed admin records
- 6 c. The system displays administrative results deleting admin data
  - 1) The system displays a list of admin records in the presence of reduced admin data

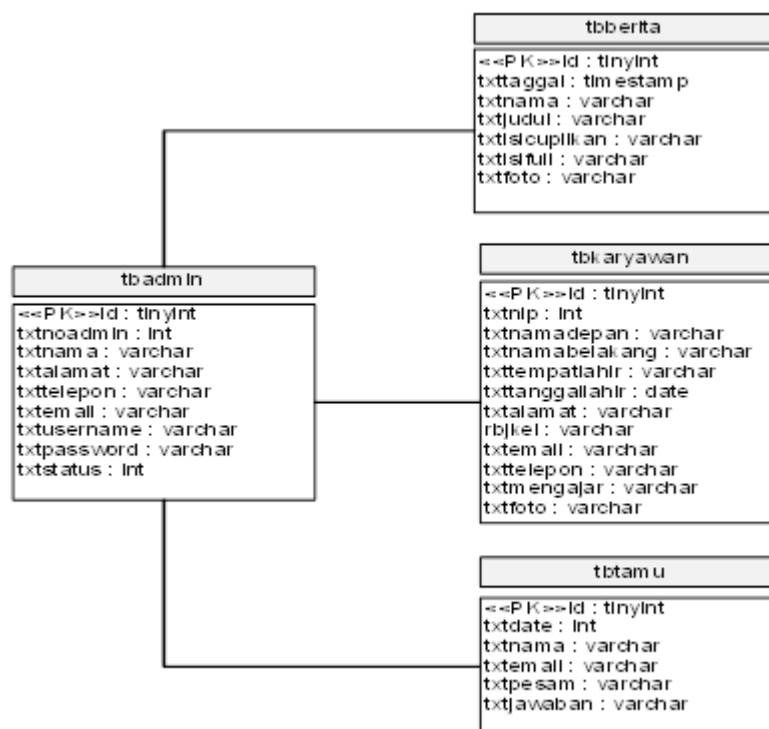

Figure 3 Class Diagram

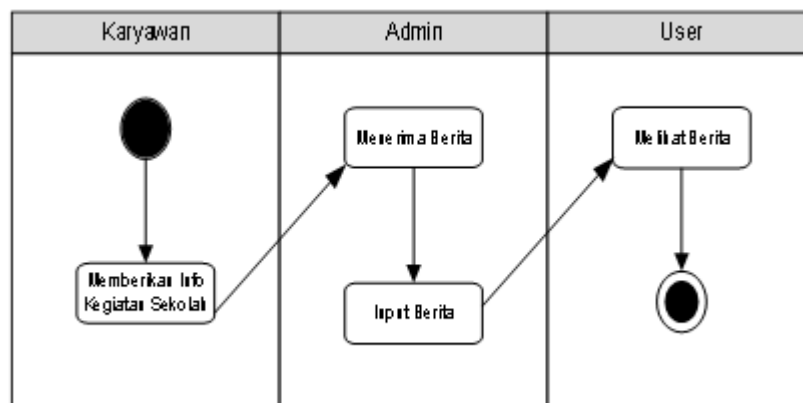

Figure 4 Activity Diagram

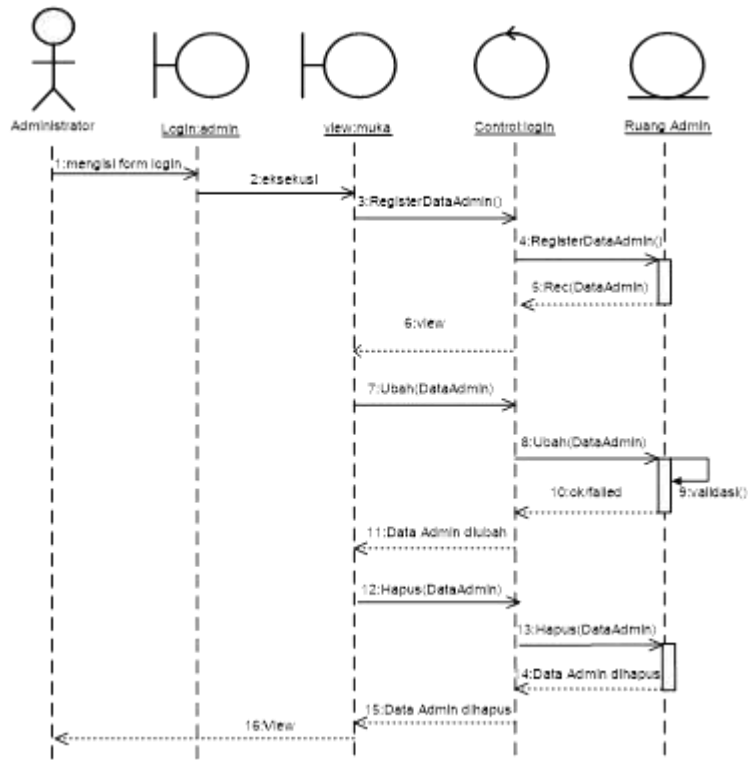

Figure 5 Sequence Diagram Input Guestbook

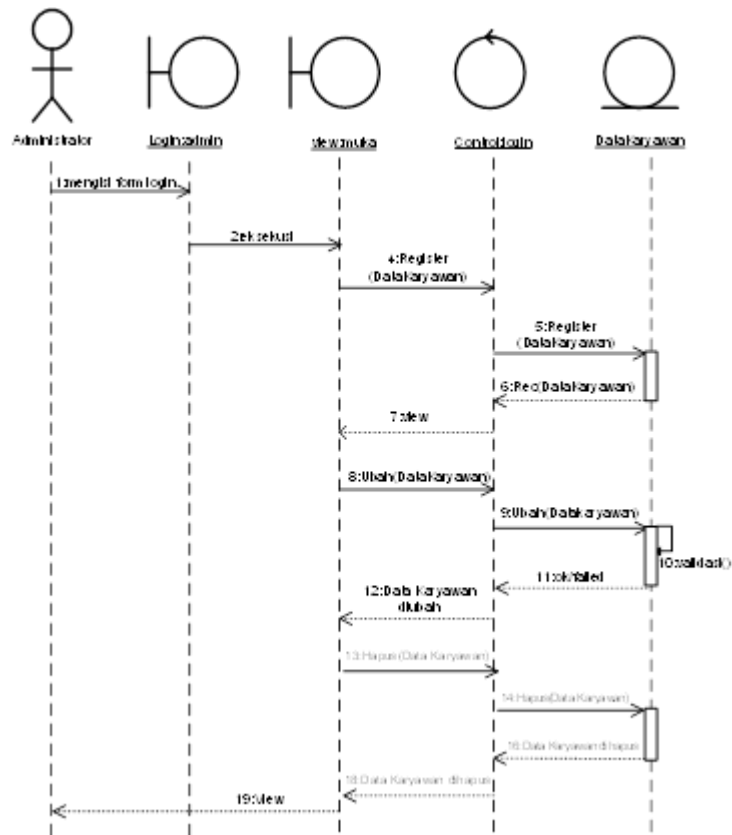

Figure 6 Sequence Diagram Data Administrator



## Conclusion

The conclusion of this study is that the author can conclude that with the creation of the school web site is expected to help promote SDN Cipete Utara 07. And with the website can provide interesting formation in various things in the school and the data can be displayed as a whole on the web site, thus making one of the attractions for people who live and are located not far from the school to enroll their children to SDN Cipete Utara 07. The author's advice is that this web-based information system runs well, the author gives some suggestions as follows:

- a. In every information that comes out, it is mandatory to include the name of the school website SDN Cipete Utara 07.
- b. Training is needed for several staff so that if there are questions from visitors who fill out the guest book can be answered immediately and also to update the latest news from the school.
- c. The need for a good internet quality improvement for schools and computer devices connected to the internet so as to facilitate data access on the web.

## References

- [1] E. Mardiani, N. Rahmansyah, H. Kurniawan, A. Muliawati, and D. S. Permana, *Membuat Aplikasi Penjualan Menggunakan Java Netbeans, MySQL, dan iReport*. Elex Media Komputindo, 2017.
- [2] E. Mardiani, N. Rahmansyah, S. Ningsih, E. T. E. Handayani, and D. Hidayatullah, "PKM MENINGKATKAN PENJUALAN UMKM BAGI PELAKU BISNIS USIA LANJUT MELALUI INOVASI ECOMMERCE DISAAT PANDEMI COVID 19," *SWADIMAS J. Pengabd. Kpd. Masy.*, vol. 1, no. 01, pp. 50–55, 2023.
- [3] E. Mardiani, N. Rahmansyah, I. B. Surniawan, and M. Sholeh, *Aplikasi Penggajian Menggunakan Visual Basic, MySQL, dan Data Report*. Elex Media Komputindo, 2016.
- [4] E. Mardiani, N. Rahmansyah, and F. Al Rizky, "Perilaku Konsumen Terhadap E-commerce disaat pandemi covid 19 di Shop and Travel," *Inform. J. Ilmu Komput.*, vol. 16, no. 3, pp. 212–217, 2020.
- [5] N. Rahmansyah, D. Mulyani, E. Mardiani, and A. Rahman, "Perancangan Sistem Transaksi Berbasis Web pada UKM Pangkas Rambut Tasik," *J. Sist. Inf. Bisnis*, vol. 3, no. 1, pp. 22–31, 2022.
- [6] E. Mardiani and F. A. Ramadhan, "Design Information System Sales of Nuts and Bolts at PT. Catur Naga Steelindo," *SITEKIN J. Sains, Teknol. dan Ind.*, vol. 20, no. 2, pp. 729–735, 2023.
- [7] E. Mardiani, N. Rahmansyah, H. Kurniawan, and D. I. Sensuse, *Kumpulan Latihan SQL*. Elex Media Komputindo, 2016.
- [8] V. Natarajan, "IoT based Smart Stick with Automated Obstacle Detector for Blind People," *2022 6th International Conference on Trends in Electronics and Informatics, ICOEI 2022 - Proceedings*. pp. 536–540, 2022. doi: 10.1109/ICOEI53556.2022.9777174.
- [9] S. Balasubramani, "Design IoT-Based Blind Stick for Visually Disabled Persons," *EAI/Springer Innovations in Communication and Computing*. pp. 385–396, 2022. doi: 10.1007/978-3-030-86165-0\_32.
- [10] J. Zhang, "Blind Post-Decision State Based Reinforcement Learning for Intelligent IoT," *IEEE Internet Things J.*, 2023, doi: 10.1109/JIOT.2023.3242613.
- [11] Z. Luo, "Independent vector analysis based blind interference reduction and signal recovery for MIMO IoT green communications," *China Commun.*, vol. 19, no. 7, pp. 79–88, 2022, doi: 10.23919/JCC.2022.07.007.
- [12] R. Mude, "IOT enabled Smart Blind Stick and Spectacles Mountable Eye-Piece equipped with Camera for Visually Challenged People," *2022 International Conference on Industry 4.0 Technology, I4Tech 2022*. 2022. doi: 10.1109/I4Tech55392.2022.9952569.
- [13] E. Mardiani, N. Rahmansyah, N. M. Wahyudi, Y. F. Wijaya, and F. Al Rizky, *Kumpulan Latihan PHP*. Elex Media Komputindo, 2021.
- [14] R. Raut, "IoT-assisted smart device for blind people," *Intelligent Systems for Rehabilitation Engineering*. pp. 129–150, 2022. doi: 10.1002/9781119785651.ch6.
- [15] H. Seo, "Multi-Sensor-Based Blind-Spot Reduction Technology and a Data-Logging Method Using a Gesture Recognition Algorithm Based on Micro E-Mobility in an IoT Environment," *Sensors*, vol. 22, no. 3, 2022, doi: 10.3390/s22031081.
- [16] M. Khosravy, "Underwater IoT Network by Blind MIMO OFDM Transceiver Based on Probabilistic Stone's Blind Source Separation," *ACM Trans. Sens. Networks*, vol. 18, no. 3, 2022, doi: 10.1145/3462674.
- [17] J. Li, "BARRN: A Blind Image Compression Artifact Reduction Network for Industrial IoT Systems,"

- IEEE Trans. Ind. Informatics*, 2022, doi: 10.1109/TII.2022.3228777.
- [18] M. T. Chen, "A practical and efficient node blind signcryption scheme for the iot device network," *Appl. Sci.*, vol. 12, no. 1, 2022, doi: 10.3390/app12010278.
- [19] K. Ogawa, "Proposal of Layer-Based IoT System Construction Method and Implementation to Rolling Stand-up Walker," *International Conference on Control, Automation and Systems*, vol. 2019. pp. 397–402, 2019. doi: 10.23919/ICCAS47443.2019.8971709.
- [20] K. Ogawa, "Proposal for a layer-based IoT construction method and its implementation and evaluation on a rolling stand-up walker," *ROBOMECH J.*, vol. 7, no. 1, 2020, doi: 10.1186/s40648-020-00176-z.
- [21] A. I. Apu, "IoT-Based Smart Blind Stick," *Lecture Notes on Data Engineering and Communications Technologies*, vol. 95. pp. 447–460, 2022. doi: 10.1007/978-981-16-6636-0\_34.
- [22] A. Alabdulkareem, N. Alhakbani, and A. Al-Nafjan, "A systematic review of research on robot-assisted therapy for children with autism," *Sensors*, vol. 22, no. 3, p. 944, 2022.
- [23] P. K. Solvang, "Between art therapy and disability aesthetics: A sociological approach for understanding the intersection between art practice and disability discourse," *Disabil. Soc.*, vol. 33, no. 2, pp. 238–253, 2018.
- [24] S. Marwecki, R. Rädle, and H. Reiterer, "Encouraging collaboration in hybrid therapy games for autistic children," in *CHI'13 Extended Abstracts on Human Factors in Computing Systems*, 2013, pp. 469–474.
- [25] R. D. L. Booth and F. G. E. Happé, "Evidence of reduced global processing in autism spectrum disorder," *J. Autism Dev. Disord.*, vol. 48, pp. 1397–1408, 2018.
- [26] S. Alarcon-Licona and L. Loke, "Autistic children's use of technology and media: a fieldwork study," in *Proceedings of the 2017 conference on interaction design and children*, 2017, pp. 651–658.